

# FOCUSOFFICESYSTEM



Focus kombiniert klassisches Design mit den Anforderungen der Zukunft. Von der einfachen Tischform bis zum funktionellen Arbeitsplatz, werden die speziellen Anforderungen durch gerundete Formen, verschiedenste Tischkombinationen und platzsparende Lösungen erfüllt.

En Focus se conjugan la estética clásica con un alto grado de funcionalidad. Desde la simple mesa hasta las islas de puestos agrupados; Focus aporta soluciones con tableros de formas ligeras, curvilineas y con infinitas combinaciones entre tableros, uniones y travesaño situado debajo del tablero.

Focus combines classical design with advanced performance. From the simple desk to the organized workplace, the functional requirements are satisfied by curved shapes, multiple combinations of desks, links and structures.

Focus unit l'esthétique classique à la fonctionnalité avancée. Du simple poste de travail aux ensembles les plus complexes, toutes les exigences opératives sont satisfaites grâce aux formes légères, aux courbes ergonomiques et aux infinies combinaisons de plateaux, liaisons et structures.

# FOCUS

**ESTETICA**  
**AESTHETICS - ESTHÉTIQUE**  
**ÄSTHETIK - ESTÉTICA**



Focus unisce l'estetica classica alla funzione più avanzata. Dalla semplice scrivania all'isola di lavoro, le esigenze operative sono soddisfatte con forme leggere, curvilinee e con infinite combinazioni di piani, raccordi e strutture.









Die farbigen Holzpaneelen oder Glaspaneelen ermöglichen einen funktionalen Arbeitsplatz.

Los paneles frontales y laterales, en colores o cristal opal, permiten la división e identificación de puestos de trabajo individuales.

The glazed and aluminium finish light screen panels efficiently separate the workspace.

Les écrans de natures différentes, verre opalin ou panneau avec mélamine colorée, permettent une division fonctionnelle et une identification du poste de travail.

# FOCUS

**SISTEMA**  
SYSTEM -SYSTÈME  
SYSTEM - SISTEMA

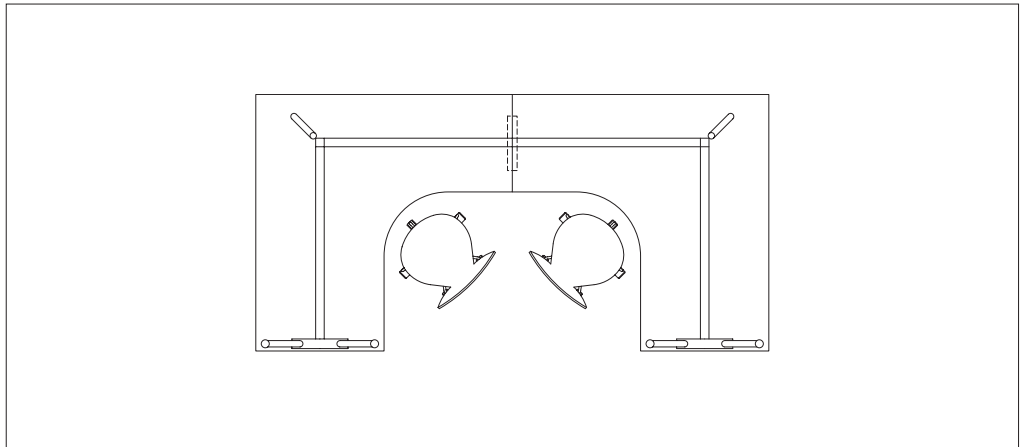

Gli screen, in vetro satinato e in finitura alluminio, permettono una giusta suddivisione e identificazione del singolo posto di lavoro.







# FOCUS

**ERGONOMIA**  
**ERGONOMICS - ERGONOMIE**  
**ERGONOMIE - ERGONOMÍA**

10 11

The elegant A-frame leg is combined with a strong metal beam.

La structure associe l'élégance des piétements chevalet à la solidité de la poutre sous-plateau.

Hinter einem eleganten A-Fußgestell verbirgt sich ein solides und stabiles Tischgestell.

En focus se conjugan la estética clásica con un alto grado de funcionalidad.

La struttura coniuga l'eleganza delle gambe a cavalletto con la solidità della trave sottopiano.

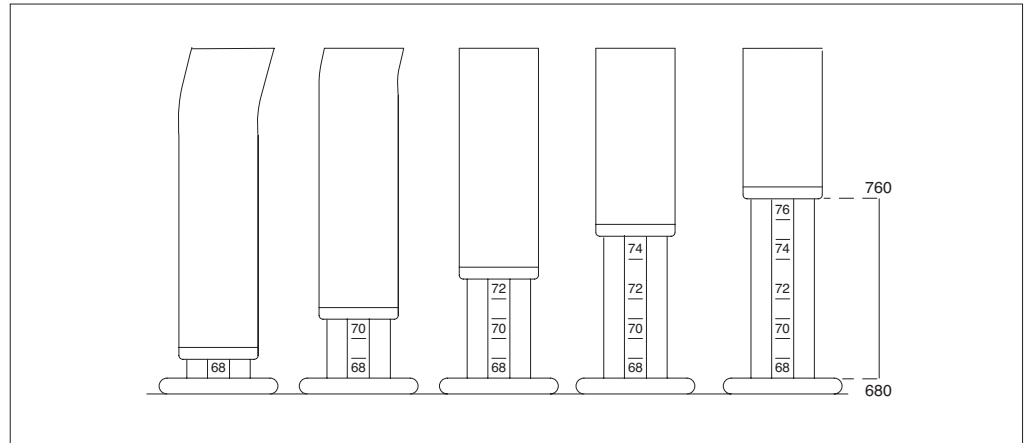











FOCUS

FLESSIBILITA'  
FLEXIBILITY - FLEXIBILITÉ  
BIEGSAHKKEIT - FLEXIBILIDAD



Una vasta gamma di accessori e di complementi nomadi consente la creazione di un ambiente molto personale, di aree comuni e riunione.



16 17

**ELEGANZA**  
ELEGANCE - ÉLÉGANCE  
ELEGANZ - ELEGANCIA

**FOCUS**

A wide range of accessories and satellites complete a very personal environment, plus meeting and conference areas.

Une vaste offre d'accessoires et compléments nomades permet la création d'un espace très personnel, d'aires communes et de réunion.

Zahlreiches Zubehör und verschiedene Trennelemente schaffen Arbeitsplätze mit sehr persönlichem Charakter sowie Kommunikations- und Besprechungsmöglichkeiten.

Una amplia gama de complementos y accesorios permiten personalizar el ambiente en la oficina ya sea en zonas comunes o de reunión.

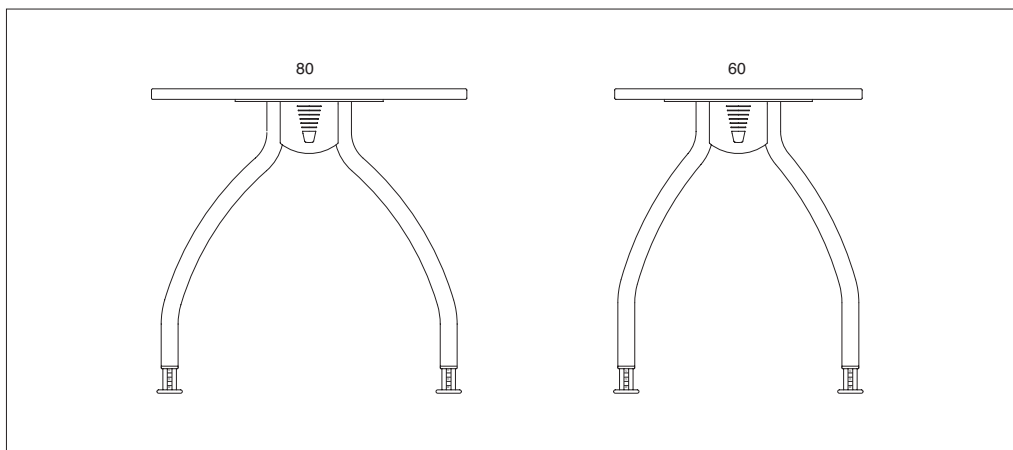

RECEPTION  
RECEPTION - RECEPTION  
RECEPTION - RECEPTION

FOCUS



# FINITURE

finishes, finitions, ausföhrungen, acabados



**32 VERDE**  
green, vert, Grün, verde



**35 BLU**  
blue, bleu, Blau, azul



**01 BIANCO**  
white, blanc, Weiß, blanco







Scrivanie - Bureaux - Desks - Schreibtische - Escritorios  
 H 72

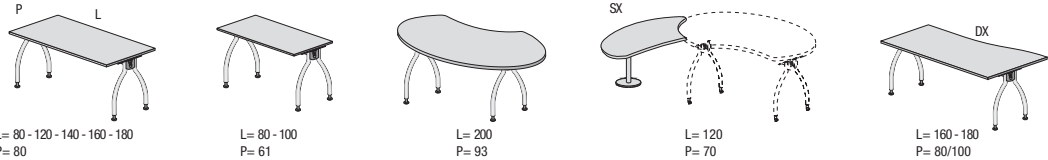

Postazioni per video terminali - Plans compacts - Workstation - EDV Tisch - WorkStation  
 H 72

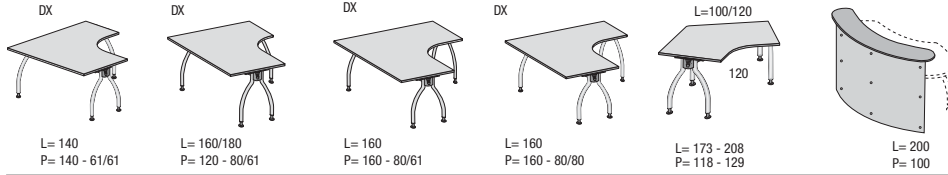

Reception - Reception - Reception - Reception - Reception  
 H 107

Penisole e raccordi - Convivialite et angles - Conference ends and links - Ambütschen und verbind ungselemente - Peninsulas y uniones  
 H 72

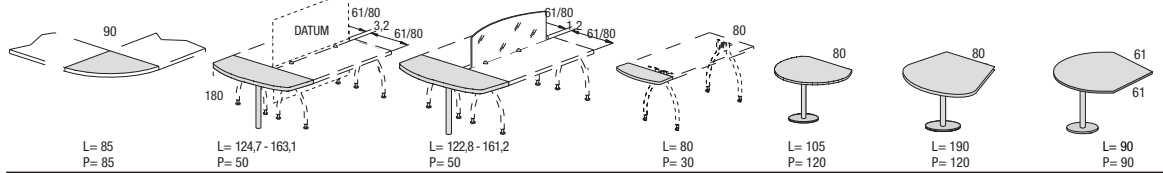

Tavoli riunione - Table reunion - Meeting tables - Konferenztische - Mesas de reuniones  
 H 72

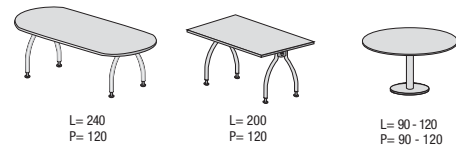

Cassettiere - Caisson - Pedestals - Container - Cajoneras  
 H 55

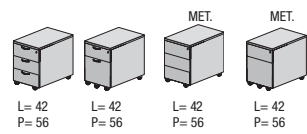

Cassettiere - Caisson - Pedestals - Container - Cajoneras  
 H 69,5

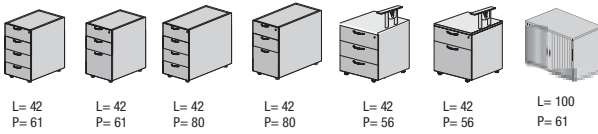

Contenitori - Cabinets - Rangements - Schranke - Contenedores  
 H 79,5

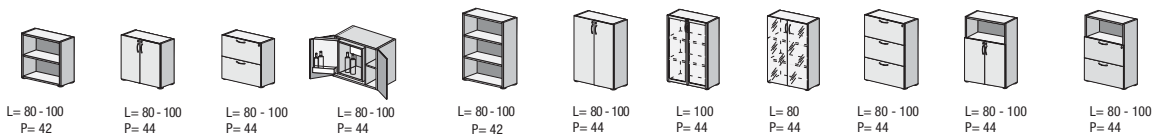

H 118

H 195

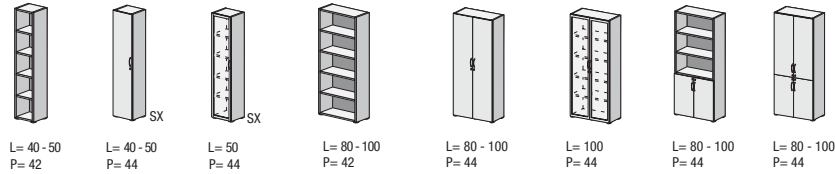

H 195

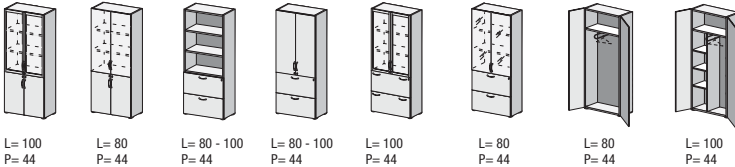

**SCREEN**

screen, panneau-écran, screen, mamparas

**00\_VETRO** glass, verre, Glas, cristal



**47\_ALLUMINIO** aluminium, aluminium, Aluminium, aluminio

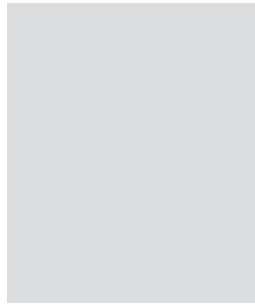

**PIANI E FRONTI**

tops & fronts, plateaux et façades, Schreibtischplatten und Fronten, planos de trabajo y frentes

**23\_GRIGIO CHIARO** light grey, gris clair, licht grau, gris claro

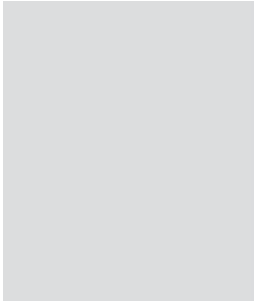

**10\_FAGGIO** beech, hêtre, buche, haya



**09\_ACERO** maple, érable, ahron, arce

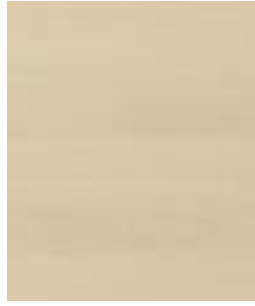

**12\_CILIEGIO CHIARO** light cherry wood, cerisier, kirschbaum, cerezo



**STRUTTURA CONTENITORI E SCRIVANIE**

cabinet & desk frames, corps d'armoires et structures, schrank- und schreibtischstruktur, estructura de armarios y mesas

**38\_GRIGIO ANTRACITE** anthracite grey, gris anthracite, antrazit grau, gris antracita

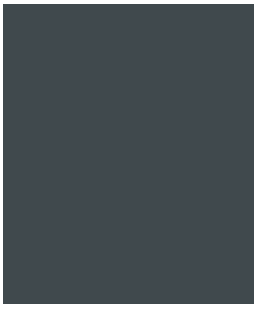

**47\_ALLUMINIO** aluminium, aluminium, Aluminium, aluminio

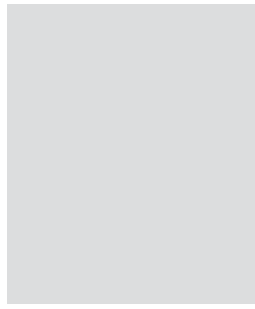

**FOCUS**

**FINITURE**  
finishes, finitions, ausführungen, acabados

concept **HANGAR DESIGN GROUP**  
photo **INDOOR**  
printed **Grafiche Antiga 2004**



**SINETICA**  
S P A

via Pirlino Fabrizio, 20 - 31046 Oderzo (TV) - Italy  
p. +39 0422 814521 - f. +39 0422 814750  
www.sinetica.com - info@sinetica.com