

# LOOP OFFICE SYSTEM



Loop ist ein Büroeinrichtungssystem, das sich durch seine Ästhetik außerhalb der traditionellen Maßstäbe auszeichnet. Dreh- und Angelpunkt ist das Fußgestell, mit einem weichen und emotionalen Design. Weiche Kurven öffnen sich nach oben, um sich mit den ergonomisch geformten Tischplatten zu verbinden.

Loop es un sistema de mobiliario para oficina caracterizado por una estética fuera de los cánones tradicionales. El elemento principal es la pata de diseño suave y emocional: curvas sinuosas para encontrar las formas ergonómicas de los Planos de trabajo.

Loop is an office furnishing system characterised by a look that breaks away from traditional norms. Its fundamental feature is a leg of soft and emotive design: winding curves rise to meet the ergonomic shapes of the worktops.

Loop est un système d'ameublement pour bureau dont l'esthétique s'éloigne volontairement des concepts traditionnels. L'association des courbes sinueuses de son piètement et les formes ergonomiques des ses plateaux en font son principal atout.

# LOOP

**ESTETICA**  
**AESTHETICS - ESTHÉTIQUE**  
**ÄSTHETIK - ESTÉTICA**



Loop è un sistema di arredo ufficio caratterizzato da una estetica fuori dai canoni tradizionali. Punto cardine è la gamba dal design morbido ed emozionale: curve sinuose salgono per incontrare le forme ergonomiche dei piani di lavoro.





Kabelkanäle (für die Elektrifizierung) und ein ergonomisches Fußgestell ermöglichen höchste Funktionalität, unzählige Kombinationsmöglichkeiten, Ergonomie und Wirtschaftlichkeit.

Vigas telescópicas (predispuestas para la electrificación) y patas compartidas, permiten elevadas prestaciones funcionales, infinitas posibilidades de layout, economicidad y ergonomía.

Telescopic beams (ready for wire management) and shared legs, allow high functional performance, infinite layout possibilities, cost saving and ergonomics.

L'utilisation de poutres télescopiques structurées (chemin de câble), en association avec des pieds partagés en division, confère à Loop des possibilités de configurations économiques infinies axées sur l'ergonomie.

04 05

**LOOP**  
**SISTEMA**  
**SYSTEM - SYSTÈME**  
**SYSTEM - SISTEMA**

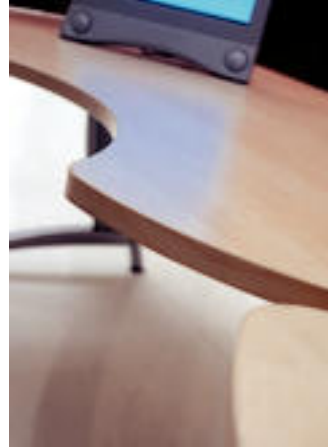
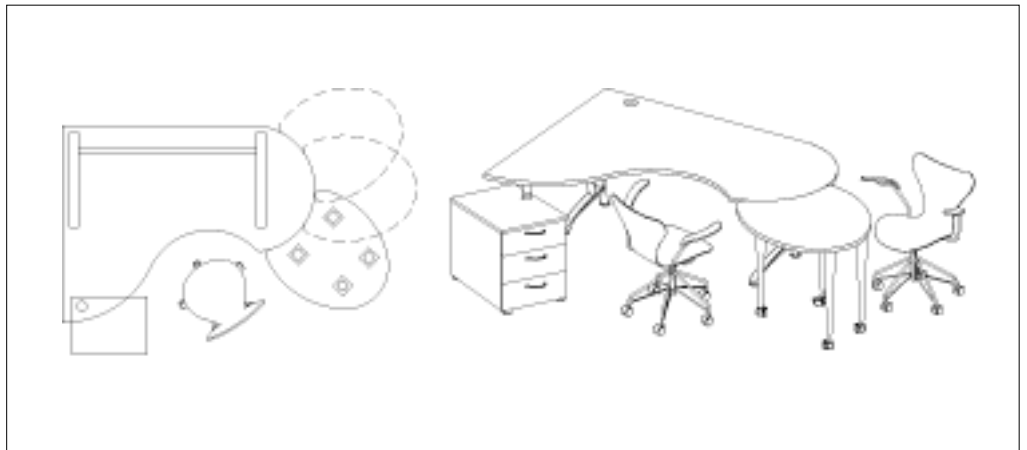

Travi telescopiche (predisposte per l'elettificazione) e gambe condivise, permettono elevate prestazioni funzionali, infinite possibilità di layout, economicità ed ergonomia.



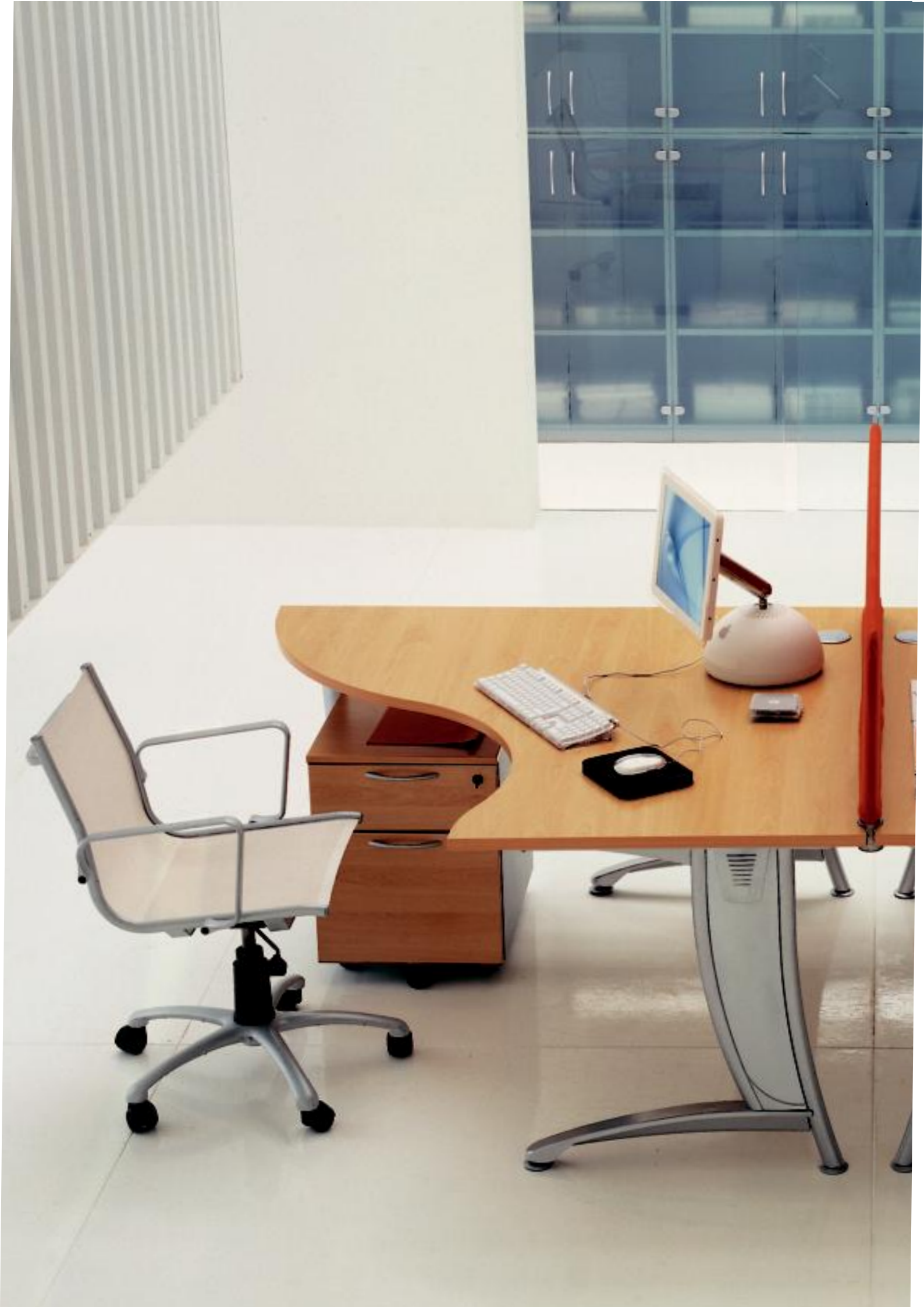

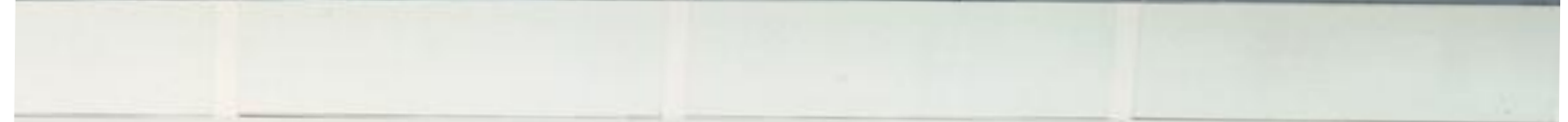



**ELEGANZA**  
ELEGANCE - ÉLÉGANCE  
ELEGANZ - ELEGANCIA

# LOOP

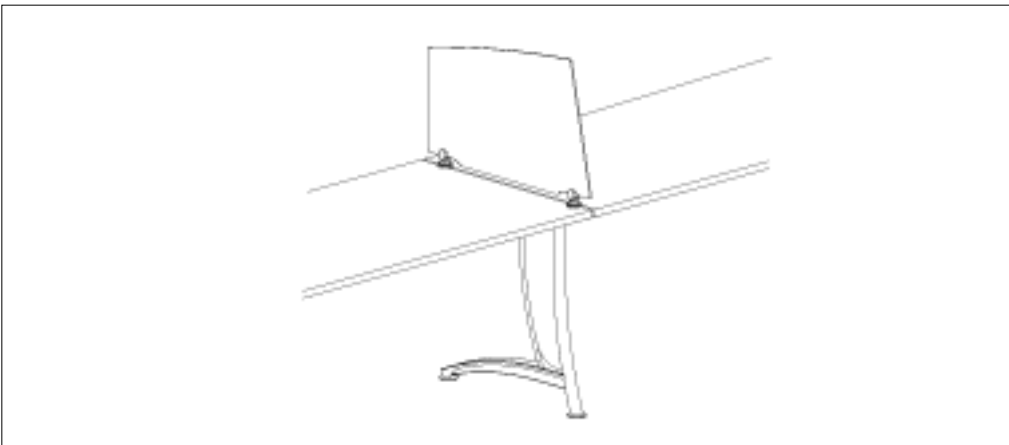
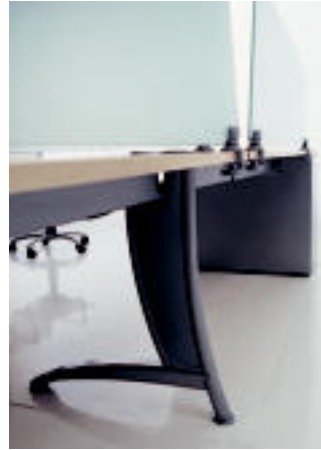





Neben den normalen Tischformen, bietet Loop eine umfangreiche Familie von Plattenformen, welche durch ihr ergonomisches Design und ihre harmonischen Kurven charakterisiert wird. Loop ist ein System mit einer Vielzahl von Arbeitsplatten, Screens, Zubehör und Kombinationsmöglichkeiten.

Junto a su rica estructura, Loop ofrece una amplia familia de planos de trabajo caracterizada por curvas armoniosas y con diseño ergonómico. Loop es un sistema rico de planos, acabados, mamparas divisorias y accesorios.

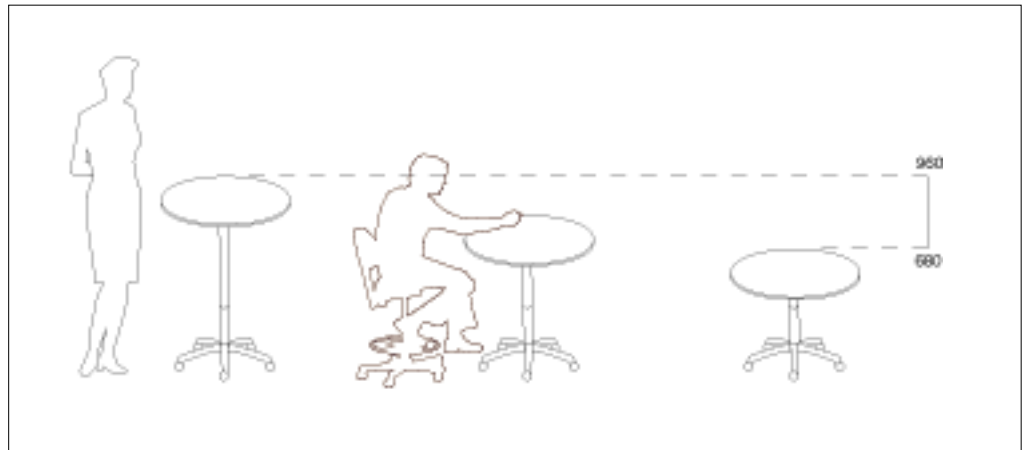

Alongside the generous frame, Loop offers a large family of worktops featuring harmonious curves and ergonomic design. Loop is a system that is abundant in tops, finishes, screens and accessories.

Grâce à sa richesse de composants, aux courbes harmonieuses, Loop offre des possibilités infinies de réalisations simples, économiques et ergonomiques.

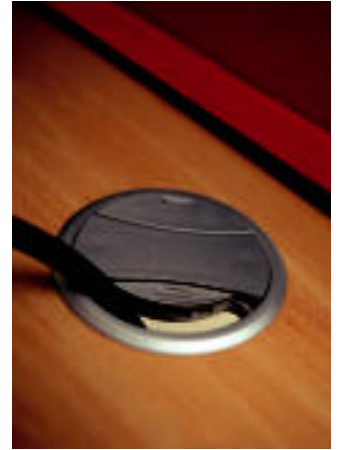

# LOOP

**SCREEN**  
**SCREEN - PANNEAU/ÉCRAN**  
**SCREEN - MAMPARAS**

Accanto alla ricca struttura, Loop offre un'ampia famiglia di piani di lavoro caratterizzata da curve armoniose e da design ergonomico. Loop è un sistema ricco di piani, di finiture, di screen e di accessori.







Die Abteilung R&D Sinetica, hat bei Loop auf ein globales Design gesetzt. Hierbei wurden moderne, chromatische Zusammenstellungen unter der Verwendung von technischen Materialien benutzt, ohne je die Funktionalität und Leistung des Systems aus dem Auge zu verlieren.

Para Loop la división R&D Sinetica ha puesto su esfuerzo en el diseño global, las armonizaciones y combinaciones cromáticas modernas así como el empleo de materiales "técnicos" sin perder de vista la funcionalidad y las prestaciones del sistema.

The R&D Sinetica department has aimed to create a global design for Loop with modern chromatic combinations and the use of technical materials without losing sight of functionality and high performance for this system.

Le département R&D de Sinetica a misé sur le design global de Loop en mariant les colorimétries modernes aux matériaux techniques performants tout en préservant sa fonctionnalité.

16 17

LOOP

FLESSIBILITA'  
FLEXIBILITY - FLEXIBILITÉ  
BIEGSAHKKEIT - FLEXIBILIDAD



Con Loop la divisione R&D di Sinetica ha esaltato il design globale, gli accostamenti cromatici moderni e l'utilizzo di materiali "tecnici", senza perdere di vista la funzionalità e le prestazioni del sistema.



**LINEARITA'**  
LINEARITY - LINÉARITÉ  
GERADHEIT - ALINEACIÓN

**LOOP**













IMMAGINE

IMAGE - IMAGE

BILDNIS - IMAGEN

LOOP

24 25





Mobilität, Besprechungsmöglichkeiten und Call-Center sind nur einige der von Loop erfüllten Eigenschaften.

Nomadismo, reunión, hot desking, call center son solo algunas de las funciones que Loop satisface.

Nomadism, meeting, hot desking and call centre are only a few of the functions that Loop fulfills.

Loop permet la réalisation de postes de travail, tables de réunion, hot desking, call center, modules nomades.

# LOOP

**RIUNIONE**  
**MEETING - RÉUNION**  
**ZUSAMMENKUNFT - REUNION**

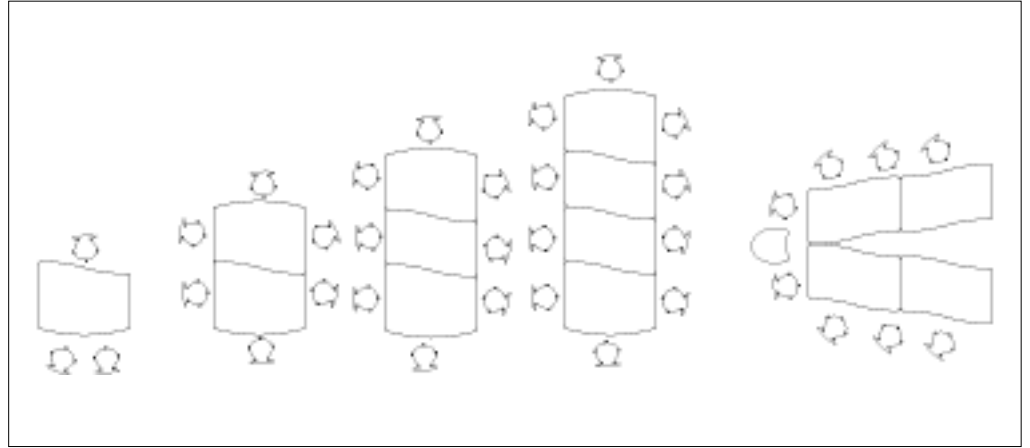

Nomadismo, riunione, hot desking, call center sono solo alcune delle funzioni soddisfatte da Loop.















**Scrivania - Escritorio - Burea - Schreibtische - Escritorio**

# 72



L= 80 - 120 - 160 - 180 - 200  
 P= 50



L= 80 - 160  
 P= 61



L= 200  
 P= 52



L= 120  
 P= 70



L= 160 - 200  
 P= 60/70

**Postazioni per video terminali - Places compacts - Escritorios - 320 Touch - Videoterminals**

# 72



L= 100  
 P= 108 - 105/1



L= 100  
 P= 128 - 105/1



L= 100  
 P= 100 - 105/1



L= 100  
 P= 158 - 105/1



L= 200  
 P= 120

**Postazioni per video terminali - Places compacts - Escritorios - 320 Touch - Videoterminals**

# 72



L= 140  
 P= 148



L= 180  
 P= 128



L= 180  
 P= 148

**Reception - Reception - Reception - Reception - Reception**

# 107



L= 200  
 P= 100

**Postazioni a ruota - Convertible at angles - Conference table and table - Aufstell- und verstellbare Tische - Postazioni p rotacion**

# 72



L= 80  
 P= 65



L= 180  
 P= 80/60



L= 124,7 - 163,7  
 P= 58



L= 122,8 - 161,2  
 P= 50



L= 80  
 P= 50



L= 90  
 P= 50



L= 88  
 P= 75



L= 85  
 P= 128

**Tavoli riunione - Table reunion - Meeting tables - Konferenztische - Mesa de reuniones**

# 72



L= 180  
 P= 110



L= 180  
 P= 65



L= 280  
 P= 120



L= 200  
 P= 120



L= 98 - 120  
 P= 58 - 58

**Capottino - Escritorio - Pedestal - Credenza - Capotino**

# 55



L= 42  
 P= 58



L= 42  
 P= 58



L= 42  
 P= 58



L= 42  
 P= 90

**Capottino - Escritorio - Pedestal - Credenza - Capotino**

# 105



L= 42  
 P= 61



L= 42  
 P= 61



L= 42  
 P= 68



L= 42  
 P= 68



L= 42  
 P= 56



L= 42  
 P= 61



L= 42  
 P= 68



L= 80  
 P= 61

**Decorazione - Gabinete - Partimenti - Schenke - Credenzas**

# 76



L= 80 - 100  
 P= 42



L= 80 - 100  
 P= 44



L= 80 - 100  
 P= 44



L= 80 - 100  
 P= 44

**Decorazione - Gabinete - Partimenti - Schenke - Credenzas**

# 110



L= 80 - 100  
 P= 42



L= 80 - 100  
 P= 44



L= 100  
 P= 44



L= 88  
 P= 44



L= 80 - 100  
 P= 44



L= 80 - 100  
 P= 44

**# 76**



L= 40 - 50  
 P= 42



L= 40 - 50  
 P= 44



L= 50  
 P= 44



L= 80 - 100  
 P= 42



L= 88 - 100  
 P= 44



L= 100  
 P= 44



L= 80 - 100  
 P= 44

**# 76**



L= 100  
 P= 44



L= 80  
 P= 44



L= 80 - 100  
 P= 44



L= 80 - 100  
 P= 44



L= 80  
 P= 44



L= 80  
 P= 44

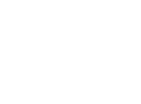

L= 100  
 P= 44

**SCREEN**  
screen, panneau-écran, screen, mamparas

**32\_TESSUTO RUGGINE**  
rust fabric, tissu rouille, Stoff ockergelb,  
tejido anaranjado



**37\_TESSUTO VERDE SALVIA** sage  
green fabric, tissu vert, Stoff salbeigrün,  
tejido verde salvia



**30\_TESSUTO LILLA** lilac fabric, tissu  
lilas, Stoff lila, tejido lila

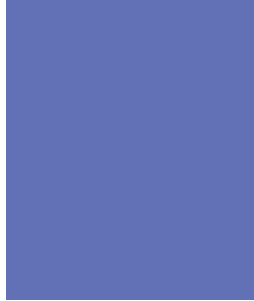

**35\_TESSUTO BLU**  
blue fabric, tissu bleu, Stoff blau, tejido azul



**SCREEN**  
screen, panneau-écran, screen, mamparas

**00\_VETRO**  
glass, verre, Glas, cristal



**47\_ALLUMINIO** aluminium, aluminium,  
Aluminium, aluminio

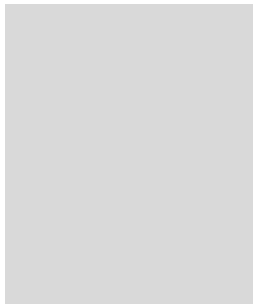

**PIANI E FRONTI**  
tops & fronts, plateaux et façades,  
Schreibtischplatten und Fronten, planos de  
trabajo y frentes

**23\_GRIGIO CHIARO** light grey, gris clair,  
lich grau, gris claro

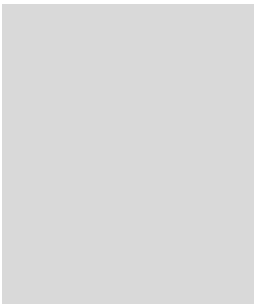

**10\_FAGGIO**  
beech, hêtre, buche, haya



**09\_ACERO**  
maple, érable, ahron, arce



**12\_CILIEGIO CHIARO** light cherry  
wood, cerisier, kirschbaum, cerezo



**STRUTTURA CONTENITORI E SCRIVANIE**  
cabinet & desk frames, corps d'armoires et  
structures, schrank- und schreibtischstruktur,  
estructura de armarios y mesas

**47\_ALLUMINIO** aluminium, aluminium,  
Aluminium, aluminio

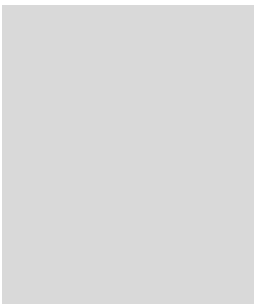

**FINITURE**  
finishes, finitions, ausführungen, acabados

**LOOP**

concept **HANGAR DESIGN GROUP**  
photo **INDOOR**  
printed **2003**



via Piniolo Fabrizio, 20 - 31046 Oderzo (TV) - Italy  
p. +39 0422 814521 - f. +39 0422 814750  
[www.sinetica.com](http://www.sinetica.com) - [sales@sinetica.com](mailto:sales@sinetica.com)